

Operating Instructions
for the
VS-2511 Solid-State Viscosity Sensor
&
VB-2510 Shunt-Diode Barrier



Examination Certificate Number	TÜV 12 ATEX 091790 X
Group, Category, Type of Protections, Temperature Classification	II 2 G Ex ib IIB T4 Gb
QAN Certificate Number	ITS12ATEXQ7518
Directive Conformity	EN 60079-0, EN 60079-11

TABLE OF CONTENTS

Introduction.....	3
Operating Principle	3
Earthing & Sensor-to-Barrier Connections.....	4
Sensor Cable Shielding	4
Signal Connections	5
Safety Information	5
Intended Use	5
Product Handling	5
Installation.....	6
Repair & Maintenance	6
Technical Data	6
Electrical Data.....	6
Electrical Parameters	6
Directive Conformity	6
Mechanical Data	6
VB-2510 Housing & Terminal Material.....	6
VS-2511 Housing Material	6
Connections.....	6
Ambient Conditions	7
Ambient Temperature	7
Storage Temperature	7
Relative Humidity	7
Terminal Assignments	7
Signal Descriptions	8

INTRODUCTION

The VS-2511 Solid-State Viscosity Sensor and VB-2510 Shunt-Diode Barrier are designed to measure viscosity and temperature of fluids in environments which require Hazardous Location classification. The two products are specifically designed to work seamlessly with one another to provide a reliable and robust connection and meet the requirements for Hazardous Location Certification.

The VS-2511 Solid State Viscosity Sensor is a fully welded sensor which measures the viscosity and temperature of fluids. The sensor is designated for installation and use in a Zone 1 or Zone 2 hazardous classified area.

The VB-2510 Shunt-Diode Barrier is an intrinsically safe zener diode safety barrier which limits excessive energy into the VS-2511 Solid State Viscosity Sensor. The barrier is designated for use and installation in a non-hazardous classified area.

Both the VS-2511 Solid-State Viscosity Sensor and VB-2510 Shunt-Diode Barrier are certified under one EC-type examination certificate.

OPERATING PRINCIPLE

The VS-2511 Solid-State Viscosity Sensor is an inherently safe device due to the use of low power electronics with very low inductance and capacitance within the welded, stainless steel housing. The sensor head is constructed of a crystal which, when in contact with fluids, changes its electrical characteristics. The sensor head also consists of a high accuracy RTD which is used to measure the temperature of the fluid. The electronics within the sensor are mounted on a printed circuit board. The sensor's electronics utilize low power (+5V) to detect changes in the crystal's electrical characteristics and temperature.

The VB-2510 Shunt-Diode Barrier is a strictly passive device constructed of current limiting fuses and resistors to protect the sensor in the event of a short-circuit fault. The barrier also has redundant zener diodes which protect the sensor in the event of an over-voltage fault. The barrier consists of one DC power channel (V+), and 5 data channels (A0, A1, SCK, MOSI, and MISO).

All channels within the VB-2510 Shunt-Diode Barrier have 50mA rated fuses. The fuse is not field repairable. The power channel has 8.2V rated zener diodes and a 51.1 ohm series resistor. The data channels have 5.6V rated zener diodes and 1k ohm series resistors. Please refer to the respective datasheets for electrical data.

EARTHING & SENSOR-TO-BARRIER CONNECTIONS

Potential Equalization (earthing) between the sensor and barrier shall be achieved by the installation of a conductor with cross-sectional area of no less than 4mm². The ground path resistance shall measure less than 1 ohm, per EN 60079-14.

VB-2510 terminals 8 and 13 shall be connected to the Potential Equalization via two separate conductors whose cross-sectional area is greater than 2mm² and not more than 2.5mm².

Earthing connections shall be made per Figure 1.

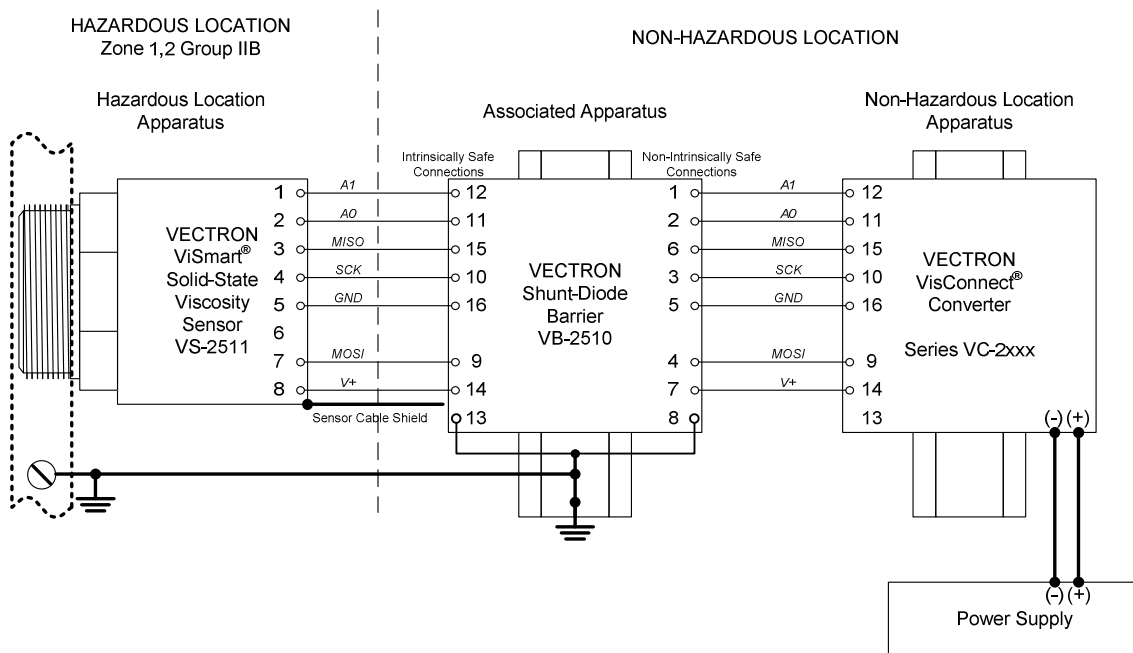

Figure 1: Connection Diagram

The VB-2510 Shunt-diode barrier is designed specifically to connect to the VS-2511 Solid-State Viscosity Sensor. Deviation from connections in Figure 1 shall invalidate the intrinsic safety.

SENSOR CABLE SHIELDING

For sensor to barrier connections, Vectron has optional sensor cables which are purchased separately. The cables are braided and foil shielded. When mated with the M12 sensor connector, the sensor cable shield is electrically connected to sensor and the cable shield is at the same electric potential as the sensor housing.

Per EN 60079-14, the sensor cable shield connection shall be made at one point only. Thus at the other end of the sensor cable, the cable shield shall be left floating. This is also shown in Figure 1.

SIGNAL CONNECTIONS

For sensor to barrier signal connections, the optional sensor cables utilize 26 awg conductors which are color coded per Table 1. All sensor to barrier signal wiring connections are also given per Figure 1 and Table 1. Wiring shall be made with 0.14 mm² to 2.5 mm² (26 awg to 14 awg) conductors. Deviation from connections in Figure 1 and Table 1 shall invalidate the intrinsic safety.

SAFETY INFORMATION

The VS-2511 Solid State Viscosity Sensor and VB-2510 Shunt-Diode Barrier Datasheets, and EC-Type Examination Certificate shall be considered part of these Operating Instructions.

INTENDED USE

The VS-2511 Solid State Viscosity Sensor and is used for measurement of the temperature and viscosity of liquids.

The VB-2510 Shunt-Diode Barrier limits voltage and current to the VS-2511 Solid State Viscosity Sensor in a Hazardous Location classified area.

The two products are specifically designed and certified for use with one another and deviation from the pairing is not permitted.

The VS-2511 Solid State Viscosity Sensor is intended for installation and use in a Zone 1, or Zone 2 classified Hazardous Location. The VB-2510 Shunt-Diode Barrier is intended for installation and use in a non-Hazardous Location.

Deviation from the intended uses may invalidate the intrinsic safety and the protection of operating personnel.

The VS-2511 Solid State Viscosity Sensor is not certified for use in a Hazardous Location if a non-Vectron barrier is installed as the associated apparatus.

PRODUCT HANDLING

Improper handling of the VS-2511 Solid State Viscosity Sensor and VB-2510 Shunt-Diode Barrier will result in voiding of the manufacturer warranty and invalidate the intrinsic safety and the protection of operating personnel. Vectron holds no responsibility for the resulting decrease in intrinsic safety if the products are not handled properly.

INSTALLATION

Installation of the VS-2511 Solid State Viscosity Sensor and VB-2510 Shunt-Diode Barrier shall be carried out by authorized personnel. Vectron holds no responsibility for the resulting decrease in intrinsic safety if the products are not installed by authorized personnel.

REPAIR & MAINTENANCE

The VB-2510 Shunt-Diode Barrier is not field repairable. Alteration of the barrier is strictly prohibited and will invalidate the intrinsic safety of the barrier.

TECHNICAL DATA

ELECTRICAL DATA

Electrical Parameters

Please reference VS-2511 & VB-2510 Datasheets.

Directive Conformity

Directive conformity is per Directive 94/9/EC. Please reference the EC-Type Examination Certificate

MECHANICAL DATA

Please reference VS-2511 & VB-2510 Datasheets.

VB-2510 Housing & Terminal Material

The housing and terminals are made of polyamide polymer, type PA66. Please reference <http://www.phoenixcon.com> for further material makeup.

VS-2511 Housing Material

The sensor housing and mating threads are made of AISI 304 Stainless Steel.

Connections

Wiring shall be made with 0.14 mm² to 2.5 mm² (26 awg to 14 awg) conductors for all non-PE terminals. The PE terminals, 8 and 13, shall be connected to the Potential Equalization via two separate conductors whose cross-sectional area is greater than 2 mm² and not more than 2.5 mm². See also the Signal Connections section of this document.

AMBIENT CONDITIONS

Ambient Temperature

Please reference VS-2511 & VB-2510 Datasheets.

Storage Temperature

Please reference VS-2511 & VB-2510 Datasheets.

Relative Humidity

Please reference VS-2511 & VB-2510 Datasheets.

TERMINAL ASSIGNMENTS

Table 1 shows the complete connection assignments required between the VC-2xxx Converters and VB-2510 Barrier as well as the connection assignments required between the VB-2510 Barrier and VS-2511 Sensor. The arrows show the direction that the signal is driven. When using the Vectron recommended cable, the signal color designations are shown below.

Table 1: Terminal Assignments

Signal Name	VC-2xxx	VB-2510		Sensor Cable Color	VS-2511
	Terminal Number	Safe Terminal Number	Hazardous Terminal Number		M12 Pin Number
A1	12	1	12	→ (white)	1
A0	11	2	11	→ (brown)	2
SCK	10	3	10	→ (yellow)	4
MOSI	9	4	9	→ (blue)	7
GND	16	5	16	← (gray)	5
MISO	15	6	15	← (green)	3
V+	14	7	14	→ (red)	8
PE	N/A	8	13	→	N/A

Signal Descriptions

A1, A0	The terminals pass the signals which encode the chip selects within a VS-25xx Series Viscosity Sensor. They are actively driven from a VC-2xxx Series Converter.
SCK, MOSO	These terminals pass the signals which carry the clock and data outputs used for the SPI bus communication between a VS-25xx Series Viscosity Sensor and VC-2xxx Series Converter. These signals are actively driven from a VC-2xxx Series Converter.
MISO	The terminals pass the signal which carries the encoded SPI bus data from the VS-25xx Series Viscosity Sensor to the VC-2xxx Series Converter. The signal is actively driven from the VS-25xx Series Viscosity Sensor.
V+	This terminal passes the DC power to the VS-25xx Series Viscosity Sensor. It is sourced from a DC-to-DC regulator within a VC-2xxx Series Converter and is typically around +7V on the input and +5.9V +/- 0.2V on the output.
GND	This terminal connection is the signal ground reference for the SPI signals and DC power.
PE	These are the Potential Equalization terminals used to safely ground the sensor and barrier per EN 60079-14.

IMPORTANT ADVISORY FOR CUSTOMERS

REGULATORY COMPLIANCE & WARRANTY

Customers are cautioned that the VS-2511 Solid State Viscosity Sensor and the VB-2510 Shunt-Diode Barrier have been tested and certified to be compliant to the EU ATEX directive as indicated by the appropriate markings on the product. Any disassembly, re-engineering, disfigurement of product markings, or installation and operation inconsistent with the directions provided in this operating manual, will render the product non-compliant and void Vectron's warranty. Any such use may also invalidate the intrinsic safety of the product and may severely affect the intended protection of the operating personnel. Vectron shall not be responsible for any consequences as a result of use of the product by customers that is not per the directions in this operating manual.
